

L SERIES



Description

The Solahart L Series is a roof mounted, open circuit solar water heater specifically designed to provide economical service in medium to high solar gain areas.

The L Series is ingenious in its simplicity. The black polyester powder coated aluminium absorber collects the sun's heat and transfers it to the water in the 6 risers. Copper is used for the risers for its high thermal conductivity ensuring the maximum amount of heat energy is passed to the water. As the water in the risers is heated, it rises into the tank to be replaced by cooler water from the tank. The solar heated water is then stored ready for use - hot water free from the sun.

The L Series has a double coated ceramic lined tank with a protective anode. The L Free Heat offers an extended warranty and includes enhanced protection, providing even longer lasting performance for absolute peace of mind.

Key Features

- Stylish slimline design
- Thermosiphon operation minimises maintenance - no moving parts
- Gas or electric booster models available
- Double coated ceramic lined tank for long life
- Enhanced protection on Free Heat model for maximum life

Key Benefits

- Save 55% to 85% of your water heating energy consumption*
- Reliable, low maintenance operation
- Hot water regardless of the weather
- Can qualify for valuable government environmental incentives*
- Reduced energy use saves up to 3.2 tonnes of CO₂ emissions every year*
- Peace of mind with 10/5/5[†] (L Free Heat) and 5/5/5[†] (L Series) year warranties

*Savings of 55% - 85% shown are based on Australian Government approved TRNSYS simulation modelling. Savings and incentives will vary depending upon your location, type of Solahart system installed, orientation and inclination of the solar collectors, type of water heater being replaced, hot water consumption and fuel tariff. Maximum financial savings off your hot water bill are achievable when replacing an electric water heater on continuous tariff.

[†]Warranty Details: 10/5/5, 10 year cylinder and collectors, 5 year parts, 5 year labour; 5/5/5, 5 year cylinder and collectors, 5 year parts, 5 year labour; applies to a single family domestic dwelling only. All other applications have either a 5/1/1/1 (Free Heat) or 3/1/1/1 warranty, 5 or 3 years cylinder, 1 year collectors, 1 year parts, 1 year labour.

Thermosiphon L and L Free Heat Open Circuit Systems

These systems are suitable for multiple installations. They are not suitable for frost or harsh water regions.

L and L Free Heat Systems

Model		150 tank	151 system	180 tank	181 system	182 system	220 tank	221 system	222 system	300 tank	301 system	302 system	303 system	440 tank	443 system	444 system
Tank model																
L		150L	✓	180L	✓	✓	220L	✓	✓	300L	✓	✓	✓	440L	✓	✓
L Free Heat		150LF	✓	180LF	✓	✓	220LF	✓	✓	300LF	✓	✓	✓	440LF	✓	✓
Collector model			L		L	L		L	L		L	L	L		L	L
No of collectors			1		1	2		1	2		1	2	3		3	4
Storage capacity	litres	150	150	180	180	180	220	220	220	300	300	300	300	440	440	440
	US gal	40	40	48	48	48	58	58	58	80	80	80	80	116	116	116
Delivery capacity (solar)	litres	130	130	160	160	160	200	200	200	260	260	260	260	400	400	400
	US gal	34	34	42	42	42	53	53	53	68	68	68	68	106	106	106
Boost capacity (electric or gas)	litres	75	75	90	90	90	110	110	110	150	150	150	150	220	220	220
	US gal	20	20	24	24	24	29	29	29	40	40	40	40	58	58	58
Weight empty	kg	49	86	55	92	125	64	101	138	81	118	151	184	124	250	260
	lbs	108	190	121	203	276	141	223	304	179	260	333	406	273	551	573
Weight full	kg	199	239	235	275	311	284	324	364	381	421	457	493	564	676	712
	lbs	439	527	518	606	686	626	714	802	840	928	1008	1087	1243	1490	1570
A – Width*	m	1.40	1.45	1.62	1.67	2.37	1.88	1.99	2.20	2.43	2.48	2.48	3.37	3.41	3.49	4.44
	in	55.1	57.1	63.8	66.8	93.3	74.0	78.4	86.6	95.7	97.6	97.6	132.7	134.3	137.4	174.8
B – Length*	m	0.51	2.53	0.51	2.53	2.53	0.51	1.72	2.53	0.51	1.72	2.53	2.53	0.51	2.53	2.53
	in	20.1	99.6	20.1	99.6	99.6	20.1	67.7	99.6	20.1	67.7	99.6	99.6	20.1	99.6	99.6

*An Additional 0.9m (35.4in) should be left on all four sides of the installation for safe access and servicing.

L Collector

Aperture (heating) area	m ²	1.87	ft ²	20	
Dimensions	length	mm	1937	in	76.3
	width	mm	1022	in	40.3
	height	mm	77	in	3.0
Capacity	litres	3	US gal	0.8	
Weight	empty	kg	33	lbs	73
	full	kg	36	lbs	79
Working pressure	kPa	1000	psi	145	
Absorber surface	Black polyester powder coat				
Absorber material	Aluminium				
Riser material	Copper tube				
Number of risers	6				
Tray material	0.7 mm aluminium				
Insulation material - base	38 mm polyester blanket				
Glass	3.2 mm tempered low iron				

Electric Boost Specifications

Heating unit type	Copper sheath immersion element			
Supply voltage	220 V – 250 V			
Recovery rate (litres/hour) @ 240 V and temperature rise of:				
Rating kW	Current Amps	30°C litres/hour	40°C litres/hour	50°C litres/hour
1.8	8	51	39	31
2.4	10	68	52	41
3.0	13	86	64	52
3.6	15	103	77	62
4.8	20	137	103	83

Gas Boost (In Tank - Optional) Specifications

Model type	FD15 gas booster fan forced
Burner rating - Input/Output	13 MJ/h / 10 MJ/h (2.8kW)
Recovery rate	59 litres per hour @ 40°C rise
Primary voltage	220 V – 250 V
Secondary voltage	12 V DC

L and L Free Heat

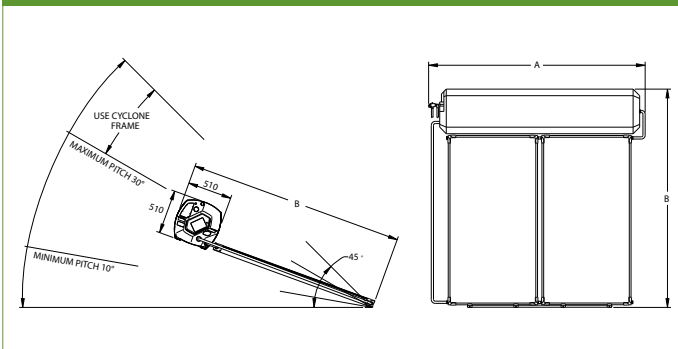

Water Supply

TPR valve setting	kPa	1000	psi	145	
ECV* setting	kPa	850	psi	125	
Max. supply pressure	with ECV	kPa	680	psi	100
	without ECV	kPa	800	psi	115
Water Connections	cold	RP ¾ / 20			
	hot	R ½ / 15			

*Expansion Control Valve